

## TECHNICAL SPECIFICATIONS

---

<b>Principle</b>	High frequency infra-red (50 KHz) Detection of signal by frequency discrimination
<b>Distance for use</b>	40 Meters in "LOW" position 80 Meters in "HIGH" position
<b>Output impulse adjustable</b>	By optocouplers and working contact. Impulse from 1/100 sec. to 2 seconds
<b>Working temperature</b>	- 20°C to + 50°C
<b>External power supply</b>	6 – 12V DC, max. current 100 mA
<b>Internal power</b>	2 x 3 batteries 1.5 V "Alcaline" Type AA or UM - 3
<b>Power reserve in "LOW" pos.</b>	100 hours at 20°C 50 hours at -20°C
<b>Power reserve in "HIGH" pos.</b>	50 hours at 20°C 20 hours at -20°C
<b>LED Checks</b>	- State of batteries - Alignment
<b>Precision of repetitive impulsions</b>	+/- 0.02 ms
<b>Dimensions</b>	2 cases of 150 x 80 x 40 mm (6x3,1x1,5 inches)
<b>Weight (incl. batteries )</b>	800 gr (29 ounces) transmitter + receiver
<b>Mounting</b>	with supports ref. HL4-3 or tripods (1/4 " camera thread)

---

<b>Maintenance</b>	Although this photocell is built to work in hard conditions, we advise you to open sometimes the aluminium cover and to let it dry when the photocell has been exposed to humidity.
--------------------	---

<b>Special Note</b>	In case you use an external power supply, we advise you to place, in any case, 3 internal batteries. These will insure the functioning of the photocell in case of current cut off or falling voltage.
---------------------	--

---

**TAG Heuer**  
**PROFESSIONAL TIMING**  
14 a, Avenue des Champs Montants  
CH-2074 Marin  
Tél. 032 / 755 60 00  
Fax 032 / 755 66 82  
E-mail: [info@tagheuer-timing.com](mailto:info@tagheuer-timing.com)  
<http://www.tagheuer-timing.com>



PROFESSIONAL TIMING

HL 2-35 PHOTOCELL

**USER'S MANUAL**

---

## DESCRIPTION

The infra-red photocell HL 2-35 is composed of one transmitter (HL 2-35E) and one receiver (HL 2-35R) with internal or external power supply and adjustment of duration of output impulse. This photocell offers exceptional quality for the price, satisfying the most exacting requirements of sports timing.

### Principle



The above photocell works perfectly with a distance between transmitter and receiver of up to 40 m. (130 ft.) in "LOW" position and up to 80 m (260 ft) in "HIGH" position.

---

## OPERATION INSTRUCTIONS

Switch on the transmitter with ② in LOW or HIGH mode.

Switch on the receiver with ②.

### a) **Battery check**

When you switch on the photocell, the LED ③ "BATT" illuminates briefly and goes out.

### I **New Batteries**

③ does not illuminate

### II **Used batteries**

③ flashes slowly (once every 2 sec.).  
The batteries insure at least 30 hours of functioning at 20° C.

### III **Flat batteries**

③ flashes rapidly (once every sec.).  
The batteries must be replaced. If this arises during the timekeeping the batteries will insure at least 6 hours of functioning at 20° C.

**WARNING**

Battery (hours of utilisation) is very much reduced under 0° C and depends on their quality. We strongly recommend to use new batteries as soon as LED ③ flashes.

**b) Lining up the photocell**

- When you switch on the receiver, the LED "SIGNAL" ④ illuminates as long as the transmitter is not lined up with the transmitter.
- First set up the transmitter on the receiver by using the sighting groove ①.
- Then aim the receiver by using the sighting groove ①. You are in alignment when LED ④ "SIGNAL" is switched off and stays so even if you move slightly the photocell.
- A luminous indicator placed under the receiving lense allows you to align accurately the transmitter on the receiver.
- Transmitter and receiver must be steadily fixed on supports ref. HL4-3 or on tripods.
- When you cut the beam between the transmitter and receiver, the LED "SIGNAL" ④ comes on. The impulse is given at the output connections ⑦.

**c) Adjusting length of impulse ⑥**

Depending on the sport to be timed, it may be necessary to have a period of time in which the apparatus is blocked between the impulses in order to eliminate interference caused by the moving body.

Min. adjustment : Duration of impulse 1/100 sec.

Max. adjustment : Duration of impulse 2 sec.

**d) Output jacks ⑦**

Open collector outlet - working contact (short circuit between black and green terminals)

Green terminal : Impulse

Black terminal : Ground

**e) Changing the batteries**

Remove the screw underneath the case. Slide the electronic unit out of the case. Change the 3 batteries observing the polarities marked on the bottom. Be sure to use good quality Alkaline type 1.5 volt batteries (UCAR Energizer E-91 e.g.). Put the electronic unit back in the case and do up the screw carefully.

**IMPORTANT**

If timing is interrupted for a long period or when it is finished:

**TURN BUTTON ② TO OFF POSITION**

**HL 2-35**

- Sighting groove
- ON/OFF switch
- Battery check
- Alignment check
- External power supply
- Impulse length adjustment
- Output jacks
- Serial number

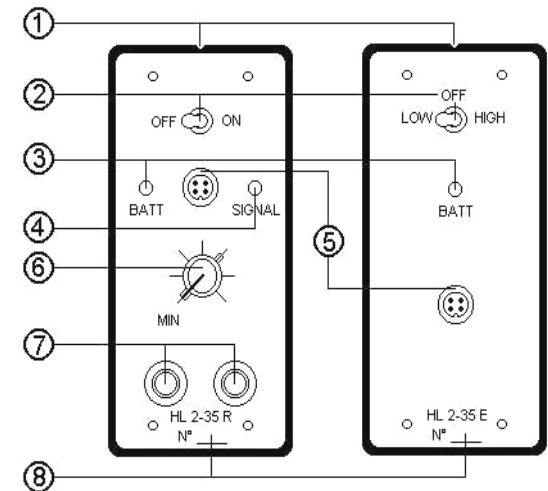
**Power connection scheme**

- Ground
- Impulse -
- 6 – 12V External Power
- Impulse +

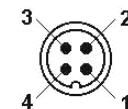

Cable to use : Ø of the sheath 3,5 à 4,5 mm (0,14 to 0,175 inch)