



PROFESSIONAL TIMING

HL 7-1 / 7-3 Start Gate

USERS MANUAL

In General

The TAG Heuer start gate responds to the most severe criteria. Its' high quality mecanical construction guarantees for remarquable accuracy and solidity in all conditions.

Specifications

- In accordance with FIS requirements, the HL 7-1 start gate features two isolated timing contacts.
- While closed, the start gate is prevented from accidental opening caused by minor knocks and bumps through the use of a blocking feature.
- Braking action built into the wand mechanism camshaft is very effective at eliminating unwanted rebound action after opening.
- The wand is installed by inserting it through the rear of the shaft holder and is held in place by a spring-mounted ball bearing.
- The start gate is fixed through a chain and screw system.

To install

- Fix the gate to a wooden start post using the chain and screw system (no need to screw to tight). The start gate must be fixed in CLOSED position.
- Insert the wand from the outer side of the wing.
- Connect different devices as shown in scheme 2.

Important

The Start gate must always be in CLOSED position when you don't use it.

Scheme 1 (top view)

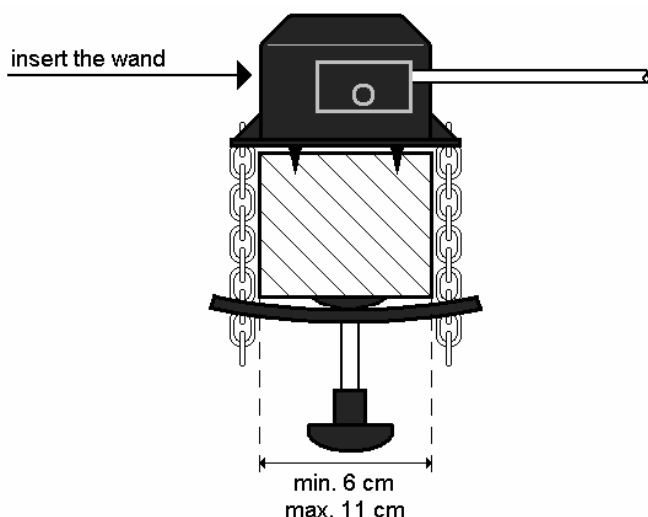

Scheme 2 (bottom view)

